



SINTEF Community
P.O.Box 124 Blindern
NO-0314 Oslo, Norway
e-mail: certification@sintef.no



Member of
www.eota.eu

European Technical Assessment

ETA-19/0566
of 2021-02-01

General Part:

Technical Assessment Body issuing the European Technical Assessment:
SINTEF

Trade name of the construction Product:

RVK and TSS connection units

Product family to which the construction product belongs:

Corbel free load-bearing steel connections for precast slabs

Manufacturer:

Invisible Connections AS
Øran
NO-6300 Åndalsnes
Norway

Manufacturing plant(s):

Invisible Connections manufacturing plant

This European Technical Assessment contains:

15 pages including 2 Annexes which form an integral part of this assessment

This European Technical Assessment is issued in accordance with Regulation (EU) No 305/2011, on the basis of:

European Assessment Document (EAD)
160069-00-0301 - Corbel free load-bearing steel connections for precast slabs

This version replaces

ETA 19/0566-v1-2019-10-21

Translations of this European Technical Assessment in other languages shall fully correspond to the original issued document and should be identified as such.

Communication of this European Technical Assessment, including transmission by electronic means, shall be in full (excepted the confidential Annex(es) referred to above). However, partial reproduction may be made, with the written consent of the issuing Technical Assessment Body. Any partial reproduction has to be identified as such.

Specific parts:

Contents

1. TECHNICAL DESCRIPTION OF THE PRODUCT	3
2. SPECIFICATION OF THE INTENDED USE(S) IN ACCORDANCE WITH THE APPLICABLE EUROPEAN ASSESSMENT DOCUMENT (HEREINAFTER EAD)	4
3. PERFORMANCE OF THE PRODUCT AND REFERENCES TO THE METHODS USED FOR ITS ASSESSMENT	4
3.1 Mechanical resistance and stability (BWR 1)	4
3.2 Safety in case of fire (BWR 2).....	5
4. ASSESSMENT AND VERIFICATION OF CONSTANCY OF PERFORMANCE (HEREINAFTER AVCP) SYSTEM APPLIED, WITH REFERENCE TO ITS LEGAL BASE	5
5. TECHNICAL DETAILS NECESSARY FOR THE IMPLEMENTATION OF THE AVCP SYSTEM, AS PROVIDED FOR IN THE APPLICABLE EAD	5
ANNEX A – ESSENTIAL CHARACTERISTICS	6
ANNEX B – INTENDED USE.....	15

1. TECHNICAL DESCRIPTION OF THE PRODUCT

The RVK and TSS connection units are in accordance with the general description in Clause 1.1 in EAD 160069-00-0301.

All connection units are rectangular hollow sections (RHS) or square hollow sections (SHS) made of cold formed structural steel S355J2H (1.0576), in accordance with EN 10219-1:2006.

The design and main dimensions are shown in Annex A.

This ETA covers the following different connection units:

Product series ¹⁾	Bridge element (inner tube)	Sliding box (outer tube)	Load categories ²⁾		
			a) <u>Without</u> simultaneously acting horizontal design support reaction $F_{V,Ed}$ [kN]	b) <u>With</u> permitted simultaneously acting horizontal design support reaction, H_{Ed} $F_{V,Ed}$ $H_{Ed} = \mu \cdot F_{V,Ed}$ [kN] [kN]	
TSS 20 FA TSS 20 FA G	SHS 40 x 40 x 4,0	-	20	20	4
TSS 25 L TSS 25 L G	RHS 50 x 50 x 5,0	-	25	25	3,8
TSS 41 TSS 41 G	RHS 70 x 40 x 4,0	RHS 80 x 50 x 4,0	40	39	7,8
TSS 60 P TSS 60 P G	RHS 80 x 40 x 5,0	Plastic	60	60	12
RVK 60 P RVK 60 P G					
TSS 101 TSS 101 G	RHS 100 x 50 x 6,0	RHS 120 x 60 x 4,0	100	94	18,8
RVK 101 RVK 101 G					
TSS 102 TSS 102 G	RHS 100 x 50 x 6,0	RHS 120 x 80 x 5,0	100	90	18

¹⁾ An additional letter G indicate hot dip galvanized version.

²⁾ The load category corresponds to the permitted vertical design reaction force (support reaction), $F_{V,Ed}$, in ULS, on the bridge element.

The position of the bridge element (inner tube) of the RVK unit is adjusted through a slot in the surface of the slab (staircase) element. The units have a safety stop at the back of the inner tube to prevent overextension.

The TSS unit is identical to the RVK unit except that the TSS unit has no opening to the upper surface. The position of the bridge element (inner tube) is instead adjusted by two strings with different colour. The units have a control line marking the correct position of the bridge element, and a hole for a locking bolt. The TSS unit is specially designed to connect precast stair- and landing elements where the final surface finish of the elements are made in the factory, for example terrazzo.

TSS 20 FA and TSS 25 L are fixed connectors without a sliding box, i.e. only with a bridge element that shall be casted directly into the precast slab with a free protruding part.

TSS 102 is a variant specially designed to reduce impact sound transmission. A rubber layer is glued to the inner tube and the dimension of the outer tube is increased in order to make sufficient space for the rubber. Beside of this, the use of the TSS 102 unit is similar to the use of the RVK/TSS 101 units.

The additional product "Masticord bearing pads" is delivered for providing equal support load distribution and elastic support in order to reduce impact sound transmission. This product can be used in case the TSS 102 unit is not applicable and reduced impact sound transmission is still required.

The pads are made of a homogeneous blend of ozone resistant rubber elastomers with a high strength random synthetic fibre cord. The bearing pads are 75 mm wide, 125 mm long and 6,5 mm thick.

The hardness is 75 shore. As additional products the manufacturer also provides "Blockout box" for TSS 41 and RVK/TSS 101, used to make recesses in the walls.

2. SPECIFICATION OF THE INTENDED USE(S) IN ACCORDANCE WITH THE APPLICABLE EUROPEAN ASSESSMENT DOCUMENT (HEREINAFTER EAD)

Intended use of the RVK and TSS connection units is in accordance with Clause 1.2 in EAD 160069-00-0301. For specification of intended use, see Annex B in this European Technical Assessment (ETA).

The performances given in Section 3 in this ETA are only valid if the connection units are used in compliance with the specifications and conditions given in Annex A and B.

The verifications and assessment methods on which this ETA is based lead to the assumption of a working life for the RVK and TSS connection units of at least 50 years. The indications given on the working life cannot be interpreted as a guarantee given by the producer, but are to be regarded only as a means for choosing the right products in relation to the expected economically reasonable working life of the works.

3. PERFORMANCE OF THE PRODUCT AND REFERENCES TO THE METHODS USED FOR ITS ASSESSMENT

3.1 Mechanical resistance and stability (BWR 1)

Essential characteristic	Performance
1) Material properties: <ul style="list-style-type: none"> - Material - Yield strength - Tensile strength 	See Annex A.1 (Table A.1)
2) Dimensions and dimensional tolerances: <ul style="list-style-type: none"> - Dimensions bridge element - Dimensions sliding box - Free space between bridge element and sliding box - Cantilever- and lever arms, including tolerances, for the intended use 	See Annex A.2 (Table A.2 and Figures A.1 to A.8)
3) Resistance under static and quasi-static loading: <ul style="list-style-type: none"> - Load category, $F_{V,Ed}$ [kN] - Load category, H_{Ed} [kN] - Design shear resistance, V_{Rd} [kN] - Design moment resistance, M_{Rd} [kNm] - Internal vertical design reaction forces, R_1, R_2 and R_3 [kN] 	See Annex A.3 (Table A.3)
4) Durability	See Annex A.4

3.2 Safety in case of fire (BWR 2)

Essential characteristic	Performance
5) Reaction to fire	Class A1, acc. to EN 13501-1: 2018
6) Resistance to fire	See Annex A.5

4. ASSESSMENT AND VERIFICATION OF CONSTANCY OF PERFORMANCE (HEREINAFTER AVCP) SYSTEM APPLIED, WITH REFERENCE TO ITS LEGAL BASE

In accordance with European Assessment Document EAD No. 160069-00-0301, the applicable European legal act is 98/214/EC.

The system to be applied is: 2+

5. TECHNICAL DETAILS NECESSARY FOR THE IMPLEMENTATION OF THE AVCP SYSTEM, AS PROVIDED FOR IN THE APPLICABLE EAD

Technical details necessary for the implementation of the AVCP system are laid down in the control plan deposited at SINTEF.

Issued in Trondheim on 2021-02-01

By

SINTEF



Hans Boye Skogstad

Approval manager

ANNEX A – ESSENTIAL CHARACTERISTICS

A.1 Material properties

Table A.1: Materials

Component	Material	Technical delivery condition	Mechanical properties	
			Yield Strength, f_y (R_{eH}) [N/mm ²]	Tensile strength, f_u (R_m) [N/mm ²]
All RHS and SHS steel sections	Cold formed structural steel S355J2H (1.0576)	According to technical documentation, EN 10219-1:2006, EN 10219-2:2006 and EN 1993-1-1:2005+A1:2014+AC2015	355	470

A.2 Dimensions

Table A.2: Main Dimensions

Dimensions:		Product series:					
		TSS 20 FA (Fig. A.1)	TSS 25 L (Fig. A.2)	TSS 41 (Fig. A.3)	TSS 60 P RVK 60 P (Fig. A.4 and A.5)	TSS 101 RVK 101 (Fig. A.6 and A.7)	TSS 102 (Fig. A.8)
Bridge element (inner tube)							
A _b [mm ²]	Cross-section area of the bridge element	535	836	775	1040	1560	1560
L _b [mm]	Length of the bridge element	215	245	275	TSS: 305 RVK: 295	TSS: 295 RVK: 300	342
L _{Max} [mm]	Max permitted extension of the bridge element (nominal value)	90	95	110	95	110	110
w _b [mm]	With of the bridge element	40	50	70	80	100	100
h _b [mm]	Hight of the bridge element	40	50	40	40	50	50
t _b [mm]	Thickness of the bridge element	4	5	4	5	6	6
Sliding box (outer tube)							
A _s [mm ²]	Cross-section area of the sliding box	-	-	935	-	1335	1836
L _s [mm]	Length of the sliding box	-	-	320	320	345	397
w _s [mm]	With of the sliding box	-	-	80	104	120	120
h _s [mm]	Hight of the sliding box	-	-	50	70	60	80
t _s [mm]	Thickness of the sliding box	-	-	4	Ribbed	4	5
Free space between bridge element and sliding box							
f _v [mm]	Free space between tubes in vertical direction	-	-	2	2-4	2	20 4 ¹⁾
f _h [mm]	Free space between tubes in horizontal direction	-	-	2	2-8	12	10
Cantilever- and lever arms corresponding to the intended use of the connection units ²⁾							
a* [mm]	Nominal value of the cantilever arm	75	120	110	95	115	115
a [mm]	Cantilever arm, including unfavourable tolerances: a = a* + Δ _a	80	120	115	95 ³⁾	120	120
b* [mm]	Nominal value of the lever arm	100	115	120	157	135	187
b [mm]	Lever arm, including unfavourable tolerances: b = b* - (Δ _a + Δ _b)	90	115	110	157 ³⁾	125	177
c* [mm]	Nominal distance between R ₂ and R ₃	-	-	155	109	160	160
b _{incr} * [mm]	Nominal value of the lever arm: b _{incr} * = b* + c*	-	-	275	266	295	347
b _{incr} [mm]	Lever arm, including unfavourable tolerances: b _{incr} = b _{incr} * - (Δ _a + Δ _{b,incr})	-	-	265	266 ³⁾	285	337
e [mm]	Nominal value of the cantilever arm from the concrete slab edge to the centre of the support area	65	80	75	60	75	75

¹⁾ Free space between rubber layer and the sliding box.

²⁾ Cantilever- and lever arms corresponding to the intended use and appurtenant achieved load categories, see Annex A.3. All tolerances: Δ_a = Δ_b = Δ_{b,incr} = +/- 5 mm.

³⁾ The plastic outer tube is made with snap-on slots to ensure correct positioning of the anchoring reinforcement, i.e. Δ_a = Δ_b = Δ_{b,incr} = 0 for TSS 60 P and RVK 60 P.

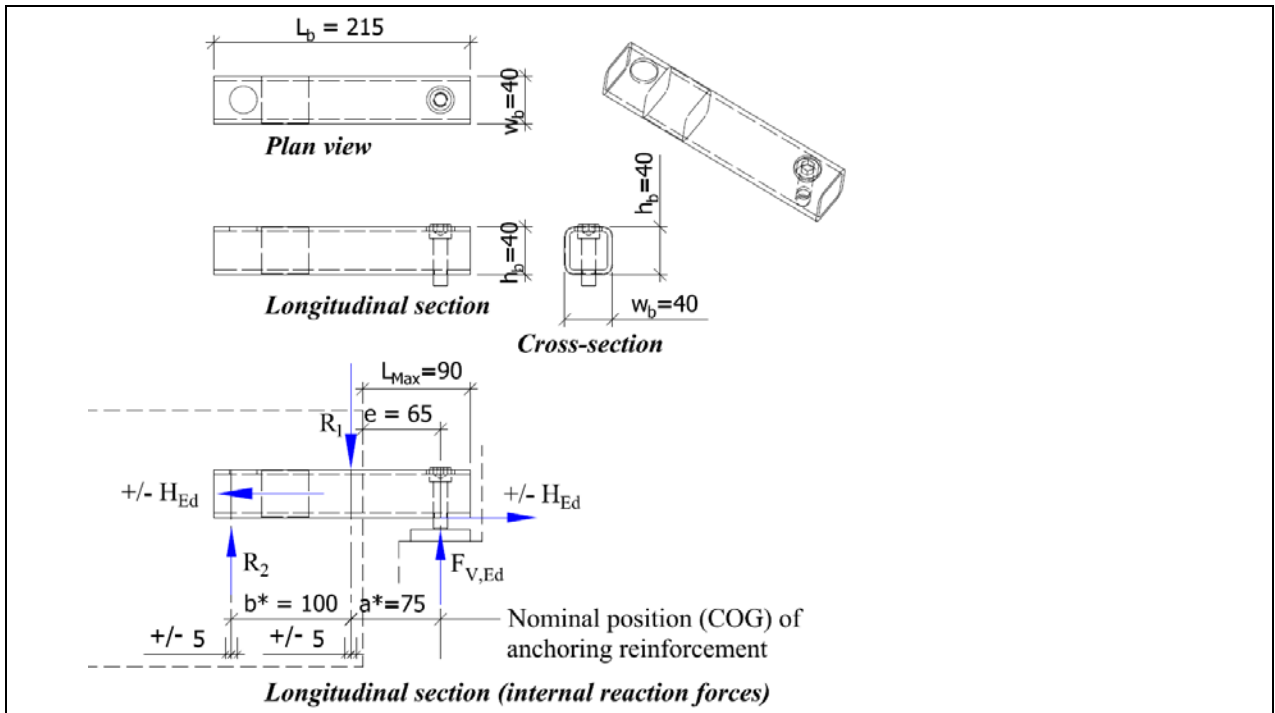

Figure A.1: TSS 20 FA and TSS 20 FA G

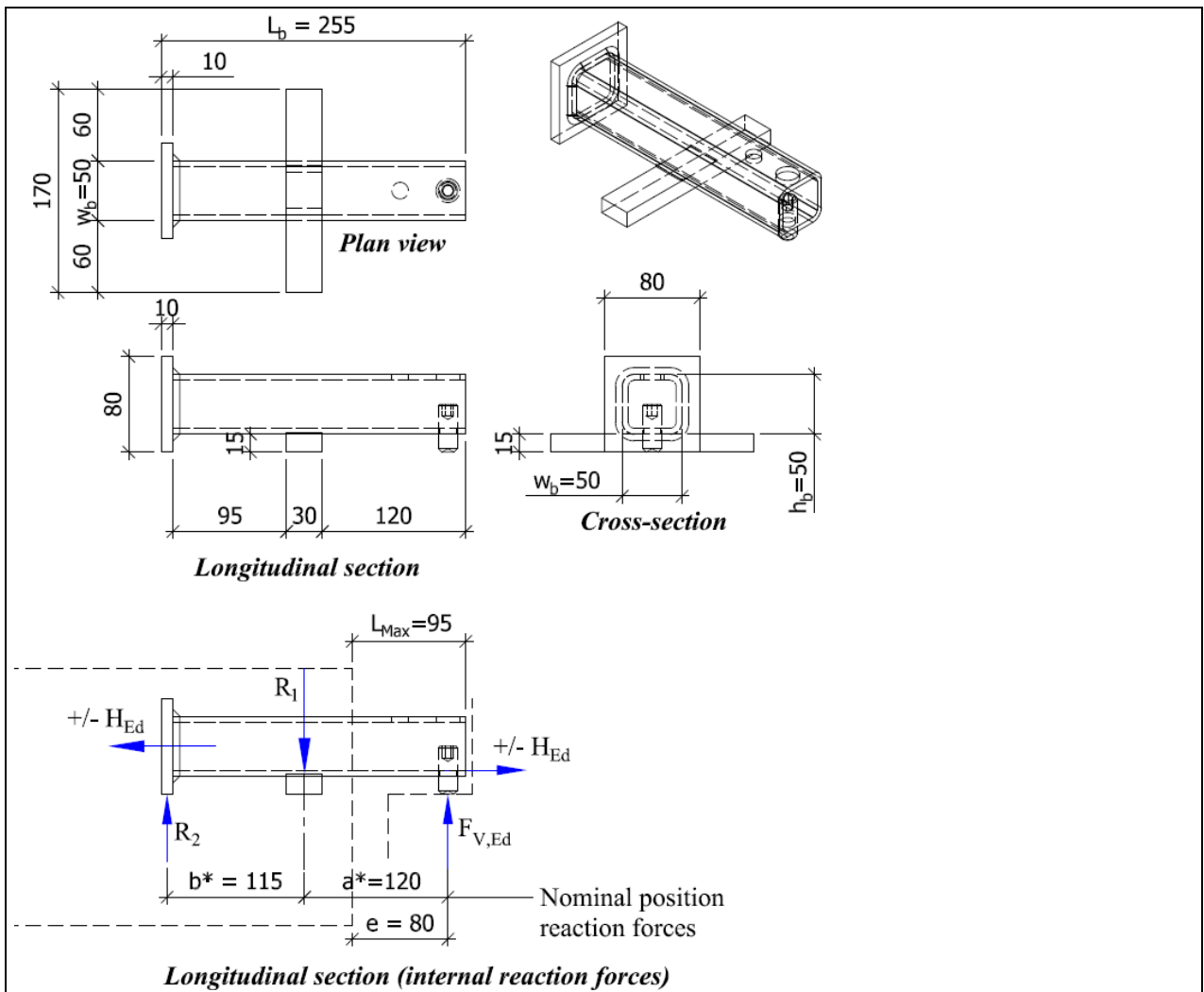

Figure A.2: TSS 25 L and TSS 25 L G

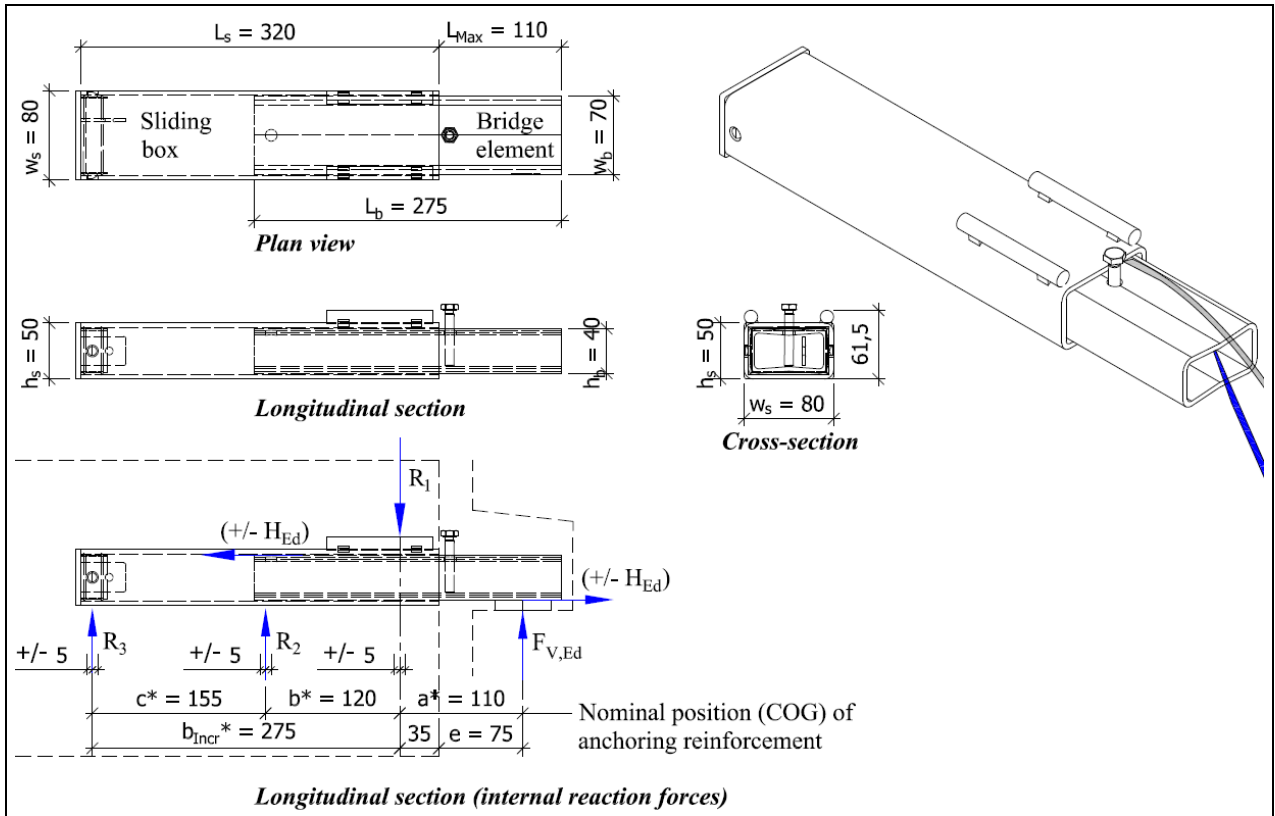

Figure A.3: TSS 41 and TSS 41 G

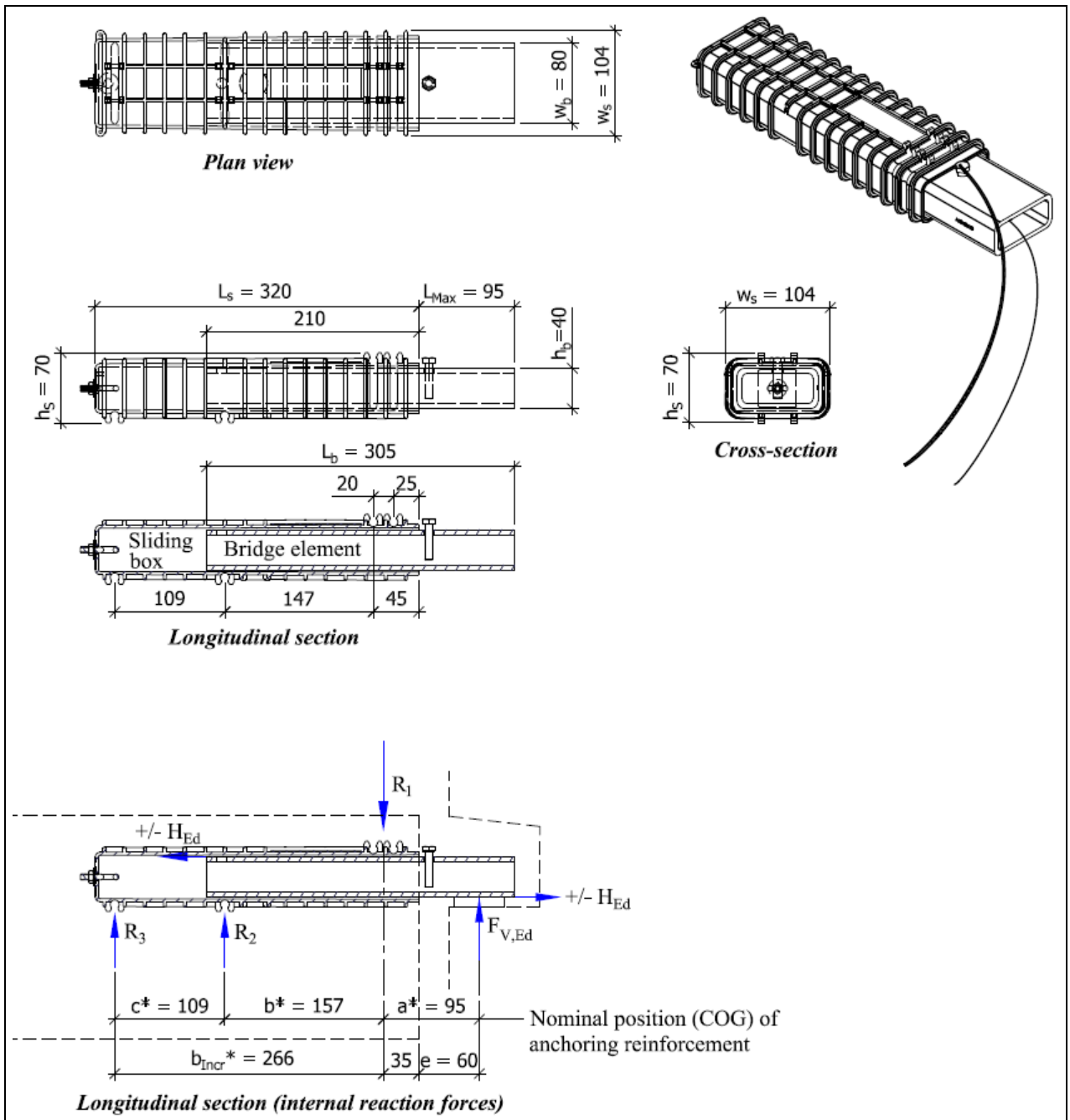

Figure A.4: TSS 60 P and TSS 60 P G

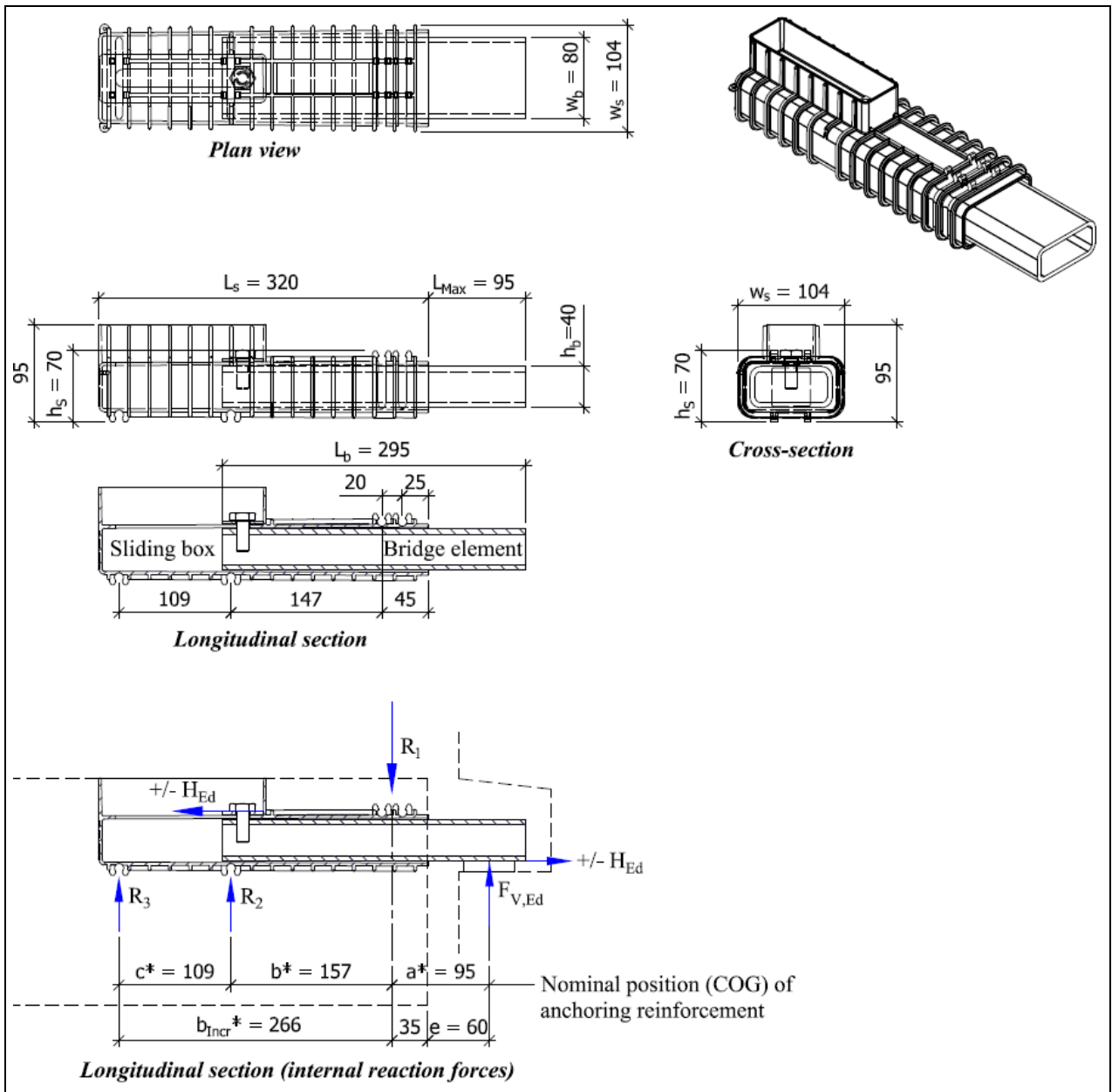

Figure A.5: RVK 60 P and RVK 60 P G

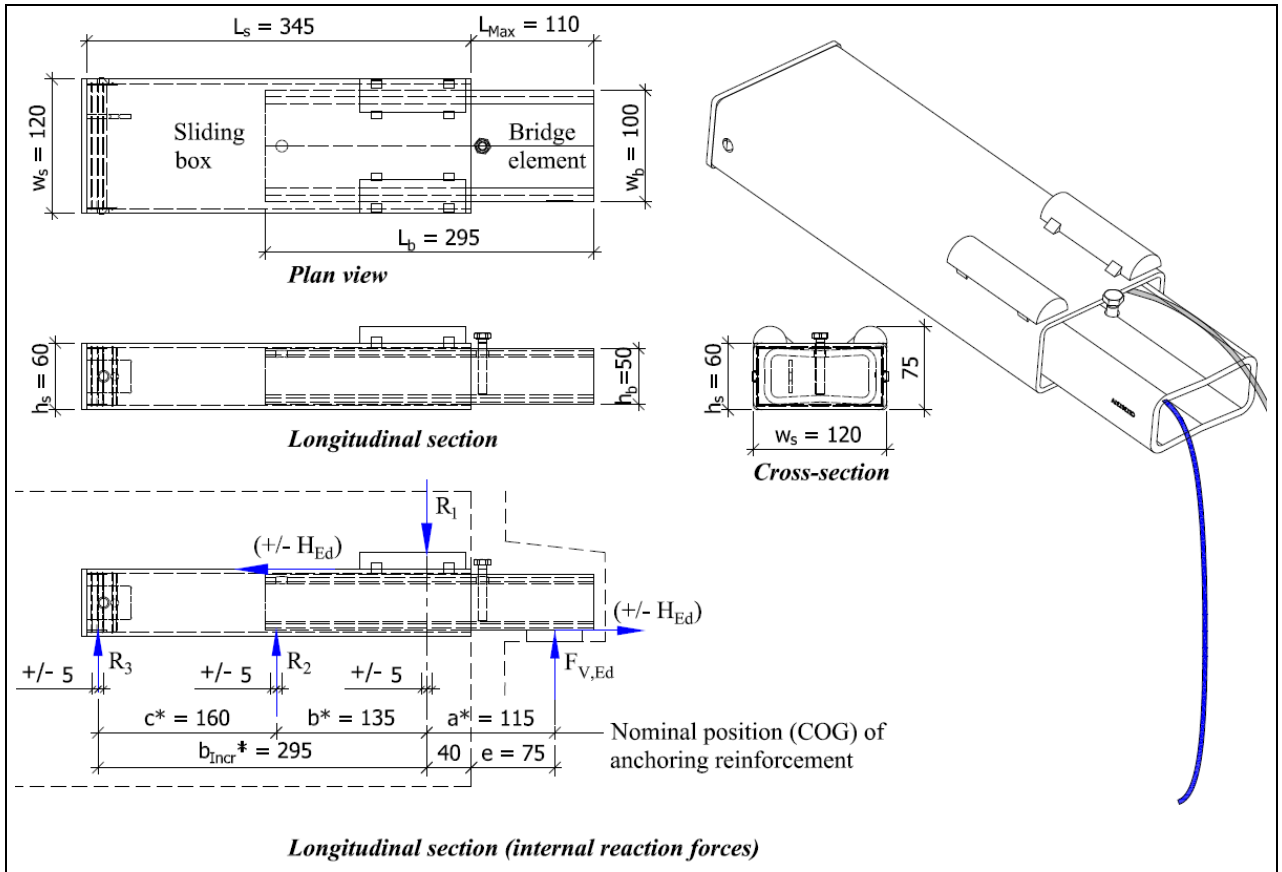

Figure A.6: TSS 101 and TSS 101 G

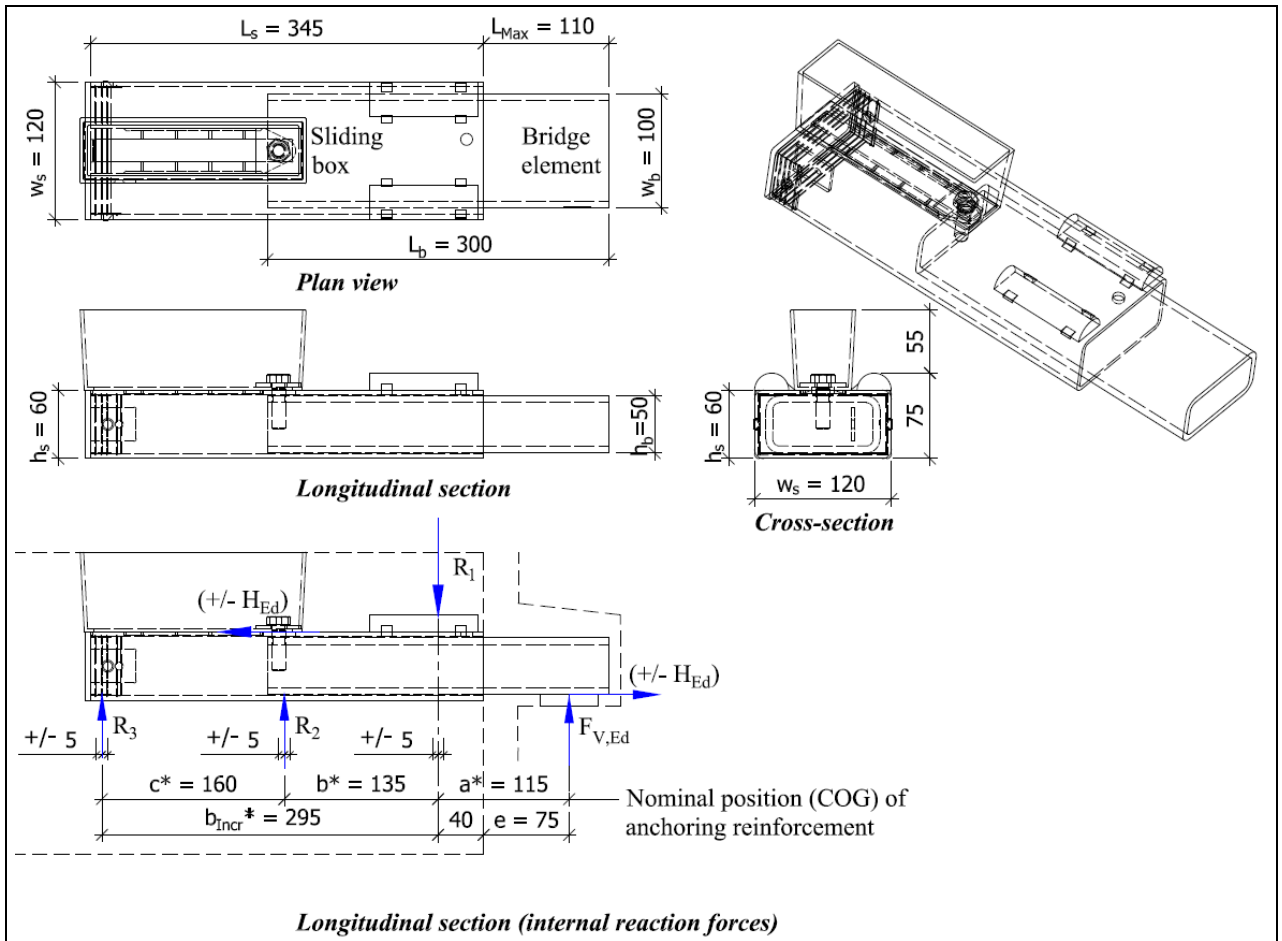

Figure A.7: RVK 101 and RVK 101 G

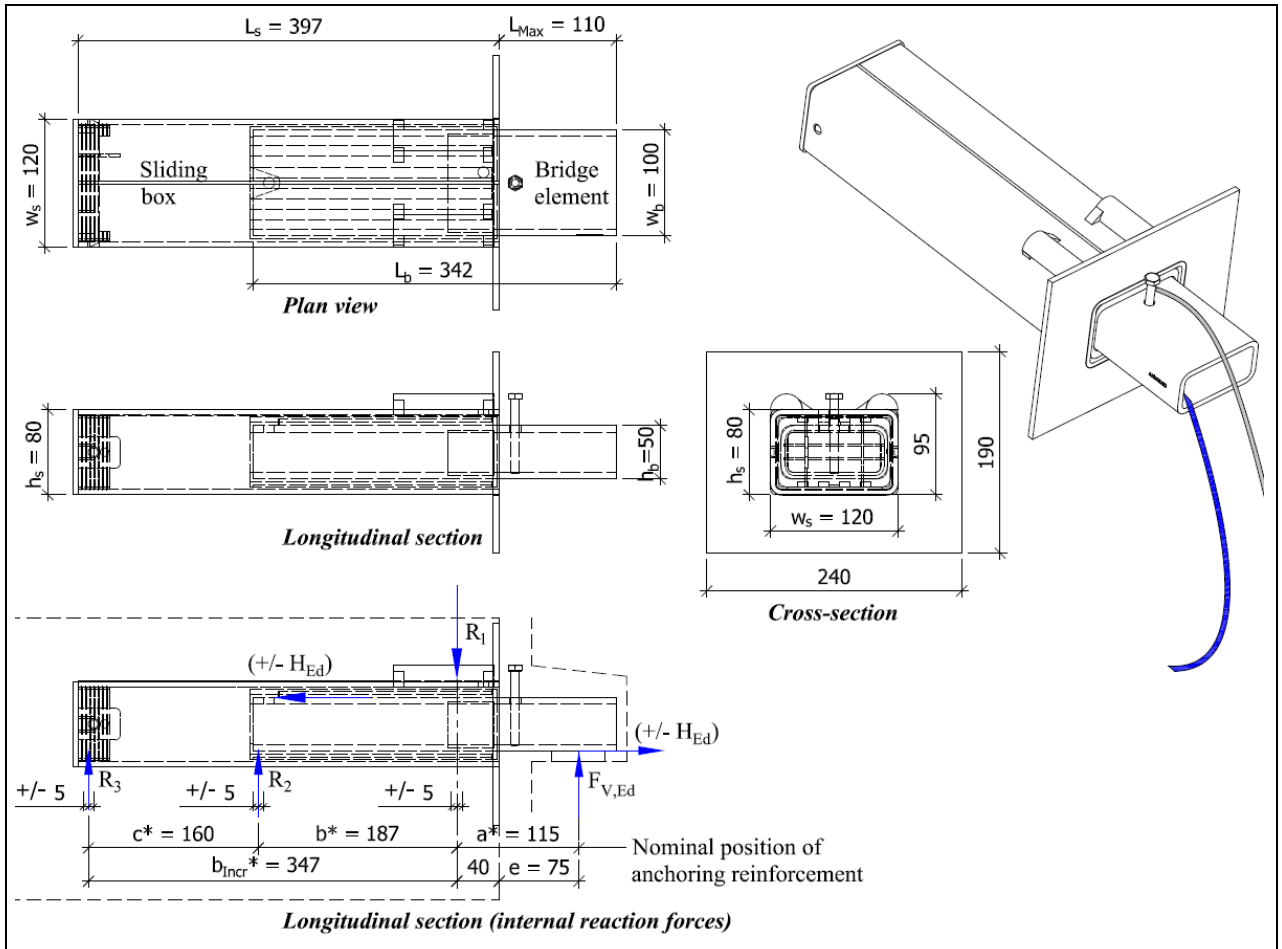

Figure A.8: TSS 102 and TSS 102 G

A.3 Resistance under static and quasi-static loading

Table A.3: Resistance under static and quasi-static loading

Performance:		Product series:					
		TSS 20 FA (Fig. A.1)	TSS 25 L (Fig. A.2)	TSS 41 (Fig. A.3)	TSS 60 P RVK 60 P (Fig. A.4 and A.5)	TSS 101 RVK 101 (Fig. A.6 and A.7)	TSS 102 (Fig. A.8)
Load categories ¹⁾							
a) Without the horizontal force, H_{Ed}							
$F_{V,Ed}$ [kN]	Permitted vertical design support reaction	20	25	40	60	100	100
b) With the horizontal force, H_{Ed}							
$F_{V,Ed}$ [kN]	Permitted vertical design support reaction in combination with simultaneously acting $H_{Ed} = \mu \cdot F_{V,Ed}$	20	25	39	60	94	90
H_{Ed} ⁴⁾ [kN]	Permitted simultaneously acting horizontal design support reaction, $H_{Ed} = \mu \cdot F_{V,Ed}$	4,0	3,8 ($\mu = 0,15$)	7,8	12	18,8	18,0
Internal design reaction forces related to the intended use ²⁾							
a) Without the horizontal force, H_{Ed}							
R_1 [kN]	At the front of the bridge element	37,8	51,1	81,8	96,3	196,0	167,8
R_2 [kN]	At the rear of the bridge element	17,8	26,1	41,8	36,3	96,0	67,8
R_3 [kN]	At the rear of the sliding box	-	-	17,4	21,4	42,9	35,6
b) With the horizontal force, H_{Ed}							
R_1 [kN]	At the front of the bridge element	38,7	51,9	82,6	99,4	191,8	156,1
R_2 [kN]	At the rear of the bridge element	18,7	26,9	43,6	39,4	97,8	66,1
R_3 [kN]	At the rear of the sliding box	-	-	18,1	23,2	42,9	34,7
Design cross section resistance of the bridge element ³⁾							
V_{Rd} [kN]	Design shear resistance	52,2	81,6	55,0	67,7	101,5	101,5
M_{Rd} [kNm]	Design moment resistance	2,4	4,6	3,8	5,1	9,6	9,6

¹⁾ Load categories (ULS) determined according to Annex A.3 in EAD 160069-00-0301.

Permitted design reaction forces $F_{V,Ed}$ and H_{Ed} determined with cantilever- and lever arms corresponding to the intended use as specified in Table A.2 in this ETA, including unfavourable tolerances.

²⁾ Internal vertical design reaction forces (R_1 , R_2 and R_3) determined according to Annex A.2 in EAD 160069-00-0301, with cantilever- and lever arms for the intended use as specified in Table A.2 in this ETA, including unfavourable tolerances.

³⁾ Design cross section resistance determined according to EN 1993-1-1:2005+A1:2014+AC:2015 with the partial safety factor $\gamma_{MO} = 1,05$. Values for V_{Rd} and M_{Rd} in this table are without interaction.

⁴⁾ The horizontal friction force, $H_{Ed} = \mu \cdot F_{V,Ed}$, calculated with the friction factor $\mu = 0,2$. This force may occur due to shrinkage and/or temperature variation in the precast slab structure.

A.4 Durability

The coating type and thickness on corrosion protected connection units are as follow:
Hot dip galvanized according to EN ISO 1461:2009. Minimum thickness of 0,08 mm.

A.5 Resistance to fire

The RVK and TSS connection units are connected to the reinforced slab concrete structure, based on the structural design for the works according to applicable design standards. To ensure required resistance to fire, the reinforced slab structure has to be designed and constructed according to the provisions of an appropriate standard for structural fire design and/or guidance rules that are developed by the manufacturer.

ANNEX B – INTENDED USE

B.1 Specification of intended use

The connection units are designed for connecting precast stairs and landing elements to the stairway shaft walls, and transferring static vertical shear loads between the concrete components. The connection units may also be used to support floor slabs mounted between walls for other purposes. Standard units are used indoor in dry conditions. Connection units made of hot dip galvanized steel may be used for external exposure according to the requirements for the individual projects.

B.2 Design

RVK and TSS connection units shall be internally supported by anchoring/suspension reinforcement inside the slab structure, as illustrated in Figures A.1 to A.8. For full utilization of the determined load categories, $F_{V,Ed}$, the reinforcement must be designed and located to correspond with the internal design reaction forces R_1 , R_2 and R_3 in Annex A.3, with 5 mm tolerance. The position of the internal design reaction forces shall correspond to the resultant force in the reinforcement.

To ensure required resistance in all limit states, the reinforced slab structure shall be designed and constructed according to the provisions of an appropriate design standard, full scale tests and/or guidance rules that are developed by the manufacturer.

B.3 Installation

RVK and TSS staircase connections shall be installed in accordance with detailed construction documentation, such as drawings, models, specifications etc., established for the specific works.

Based on combination of performed calculations- and full scale tests of embedded connection units, the manufacturer may accompany the RVK and TSS connection units with guidance rules developed for its use, including instructions for given specific design- and installation situations.